



STREAMLINE YOUR OPERATIONS WITH PROVEN INNOVATION

Honeywell Perfection Gas Distribution Products

Honeywell



QUALITY YOU CAN RELY ON. PERFORMANCE YOU CAN BANK ON.

Honeywell Perfection products are based on one firm conviction: When we partner with utilities and gas-distribution companies to learn the challenges you face, we develop products that bring real value to you and your customers.

That's been our mission for more than 40 years – and we've heard what real value means to you. Gas-distribution that is both safe and cost effective. Devices that work for years with minimal maintenance. Installations one person can do in a few brief minutes with a few basic tools – even in bad weather.

And when you can trust your gas-distribution products to do all that, there's only one word for it: Perfection.



TABLE OF CONTENTS

Permasert™ 2.0 Mechanical Gas Couplings _____	4
PermaLock Mechanical Tapping Tees _____	6
Excess Flow Valves for Gas Service Lines _____	8
Permasert XL Large Diameter Mechanical Couplings _____	10
Gas Risers and Transition Fittings _____	12
Retrofit Components and Custom Parts _____	14

THE PROVEN COUPLING, NOW WITH INNER AND OUTER SEALS

For more than 40 years and 50 million installations, Permasert™ couplings have meant safe, reliable gas distribution. And the Perfection Permasert 2.0 from Honeywell builds on that success with an innovative design that features ID and OD seals.

The result: Faster connections at lower cost in virtually any weather, now with two layers of gas-tight protection against leaks and imperfections.

PROTECTION INSIDE AND OUT

ID and OD seals provide greater protection against nuisance leaks and pipe variations.

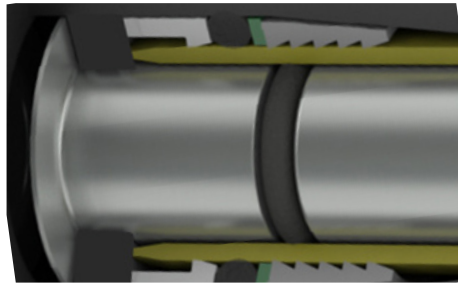

INNER DIAMETER SEAL: Helps protect against nuisance leaks from scratched pipe.

OUTER DIAMETER SEAL: Helps protect against variations in wall thickness.

LOWER COSTS, FEWER HASSLES

A Permasert fitting creates a permanent seal just as a fusion joint does – yet a Permasert installation is much faster. You'll also reduce your costs for tools and labor, and can complete installations in a wider range of conditions, with fewer limits and complications.



Easy installation in as few as 5 minutes with tools that fit in a pocket.



Get a permanent seal without rescheduling: Install in nearly any weather or other dirty conditions.



Training takes only 1 hour, vs. 4+ hours for electrofusion and conventional fusion fittings.



Cleaner and greener: No power source needed, no noise, no pollution.



SPECIFICATIONS

BODY

Gas Grade Polyethylene (PE4710)

Collet: Acetal (POM)

Thrust Washer: Polyethylene (PE)

Seals: BUNA-N (Nitrile)

Spacer Retainer Ring: Acetal (POM)

Stiffener: Zinc-Plated Carbon Steel

TESTING

Pull-Out Resistance:

ASTM D2513 Category 1

- 0.2 ipm
- 20 ipm
- Full Seal + Full Restraint, PE Yields

Hydrostatic:

 ASTM D1598

- - 670 psi (4.6 MPa) Hoop Stress
- - 176°F (80°C)
- - Pass

Quick Burst:

 ASTM D1599

- Pass

PRESSURE RATINGS

Couplings are designed to meet or exceed the maximum allowable operating pressure (MAOP) requirements of the piping system: 125 psig MAOP, or the rating of the installed tubing.

SIZES

½ in. CTS through 2 in. IPS

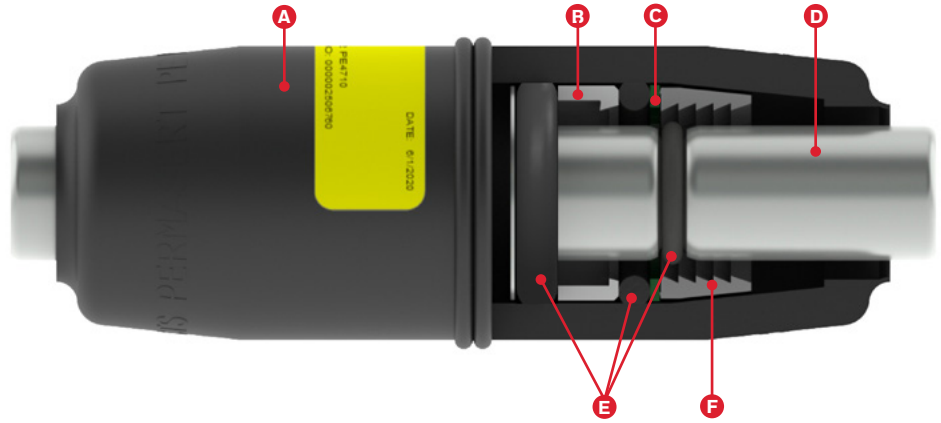

A Permasert 2.0 Coupling: Molded from PE4710 resin. Meets or exceeds US DOT Part 192; ASTM D2513, Category 1; ASTM F1924; NFPA 58; CSA 137.4. IAPMO/UPC listed.

B Spacer Retainer Ring: Centers pipe and provides a redundant activation mechanism for the collet.

C Thrust Washer: Provides even distribution of force on the collet.

D Stiffener: Zinc-plated steel stiffener guarantees proper alignment and adds support for full restraint.

E Seals: BUNA-N (Nitrile) elastomers provide a redundant sealing system.

F Collet: Tapered gripping collet prevents pipe pull-out.

INSTALLATION PROCEDURE



1. Cut the tubing so that the end is square.



2. Wipe the tubing with a dry, clean cloth.



4. Insert tube and rotate in chamfer tool until tube bottoms out.



5. Mark the stab depth.

3. Inspect the tubing for surface defects.

Note: This quick-install image guide is for reference only. Permasert 2.0 couplings require training on the complete installation procedure before installing any Permasert 2.0 product.



6. Stab tubing into the coupling until it bottoms out.

7. Pressure test the finished joint according to your standard operating procedure.

FAST CONNECTIONS WITHOUT INTERRUPTION

The Perfection PermaLock™ mechanical tapping tee offers gas line installers a unique combination of speed, economy, and security when connecting a service line to a gas main.

PermaLock tapping tees can be installed in as little as five minutes without the need for expensive fusion equipment. The simplicity of this installation eliminates the need for extensive training and multi-person crews. In fact, PermaLock tees can be installed without even shutting down the main.



SAFETY AND CONVENIENCE

PermaLock tapping tees use a full-encirclement design to ensure a reliable, gas-tight connection. The tee features a patented ratchet-style cutter that not only creates the port for gas flow, but securely locks the tee onto the gas main with a unique double-locking design that prevents movement or loosening of the connection. The cutter's locking sleeve is also designed for minimal protrusion into the main, enabling efficient pigging of the line.

20 YEARS OF RELIABLE OPERATION

- Easy installation in as few as 5 minutes with simple tools and PermaTite™ hand tightened cap
- Full-encirclement and double lock design improves safety and long term performance
- Large gas port (0.90" on 2" to 12" mains) to ensure high flow capacity
- Available with Permasert™ or fusion outlets with optional integrated Excess Flow Valve (EFV)
- Non-Interrupt Service Transfer (NIST) model allows transfer of 1" CTS and 1 ¼" CTS service to replacement line without interrupting flow of gas

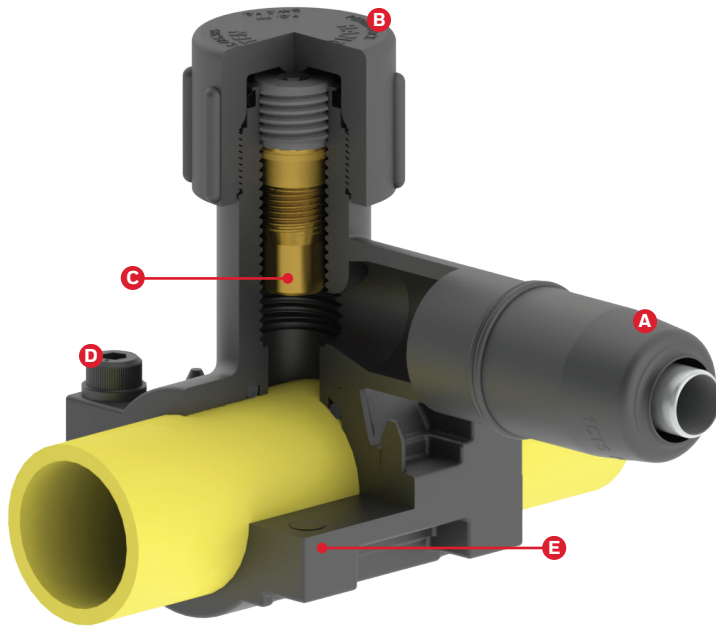

SPECIFICATIONS

BODY

PE3408/PE4710

- 20 to 60x more resistant to SCG
- Compared to PE2406 and PE3408
- Over 6,000 hours PE Notching test

Approvals

- US DOT Part 192
- ASTM D 2513
- CSA B137.4

SIZES

- Main sizes of 1-1/4" IPS, 2", 3", 4", 6", 8"
- NIST model 1" CTS and 1-1/4" CTS
- Permasert or fusion outlet sizes from 1/2" CTS to 2" IPS
- Saddle and Electrofusion tapping tees available
- Metric and custom configurations available

- A** Permasert 2.0 Coupling
- B** PermaTite Cap
- C** Two-Piece Cutter assembly with locking Sleeve
- D** 4 connection Bolts: 2 stainless steel straps for PMTT's 6" and larger
- E** Full Encirclment Tapping Tee
- F** Excess Flow Valve (Optional). Not Shown

INSTALLATION PROCEDURE

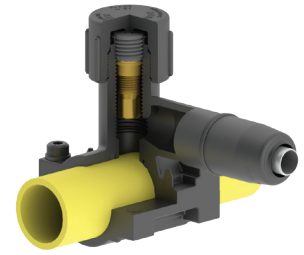

1. PermaLock full-encirclement tee is bolted onto the main.



2. Patented ratchet-style cutter assembly is threaded into the main.

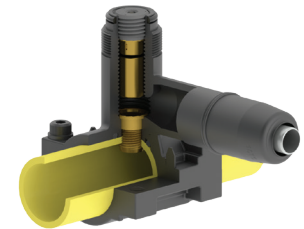

3. Cutter is reversed until flush with the top of the tower. Locking sleeve remains permanently threaded into the gas main.

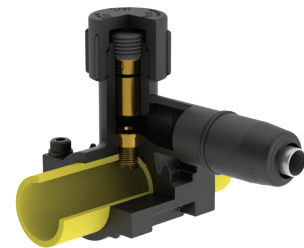

4. Cap is threaded onto tower. PermaLock tapping tees provide a .80" port for high gas flow (.55" in 1-1/4" mains).

INNOVATION THAT MAKES GAS DELIVERY SAFER

Make installation of excess-flow valves as easy as Perfection: We incorporate EFVs directly into Perfection products such as our Permasert couplings and PermaLock tapping tees to help you ensure safe, effective gas delivery.



AUTOMATIC SEALING AND RESET

Perfection EFVs prevent catastrophic leakage by tripping automatically: When gas flow reaches a critical rate, the force on a ball exceeds the opposing force on a spring, which causes the ball to seal against a seat.

Reset is also automatic: Once downstream damage is corrected, a bleed-by or bypass flow of gas lets upstream and downstream pressures equalize, resetting the valve to its open position. (A full-shut-off EFV is also available, which must be reset manually.)

SAFE AND DEPENDABLE

Perfection EFVs are designed for reliable, maintenance-free operation with trip-flow rates of 400, 600, 800, 1100, or 1800 standard cubic feet per hour (SCFH), measured at 10 pounds per square inch gauge (psig).

The EFV design and large port area let particulate matter pass through the valve without damage or buildup. Perfection EFVs provide extremely consistent trip-flow rates and very low pressure drop across the valve. Carefully controlled bleed-by assures automatic reset at a pressure differential as low as 1.5 psig.

AS SIMPLE AS PERFECTION

- Integrated directly into Permasert couplings, PermaLock tapping tees, polyethylene sticks, and more.
- Self-actuating valve with precise trip-flow rate.
- Automatic reset when line pressure equalizes. Full-shut-off design also available.
- Metallic valve housing provides consistent operation without binding in coil PE tubing.

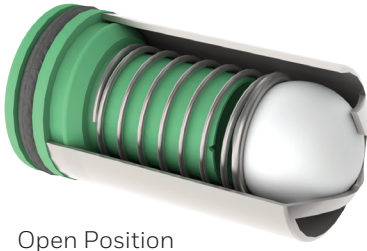
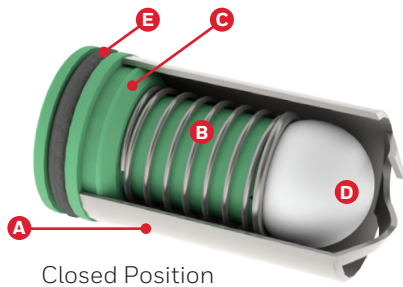

SPECIFICATIONS

COMPONENTS

- A** Valve Housing – 300 Series Stainless Steel
- B** Spring – 300 Series Stainless Steel
- C** Port Tube – Acetal Copolymer
- D** Ball – Precision ground nylon
- E** O-ring – Buna-N (Nitrile)

APPROVALS

MSS SP-115
 ASTM F 1802
 ASTM F 2138
 US DOT CFR Title 49, Part 192.381
 100% factory tested

FLOW SIZES

400, 600, 800, 1100, 1800 CFM
 (measured at 10 psig)

AVAILABLE CONFIGURATIONS

Permasert Couplings
 Permalock Mechanical Tapping Tees
 Stick and Stick-by-Permasert
 Heat Fusion Tapping Teals
 PSV/EFV Combo Shut-off Valves

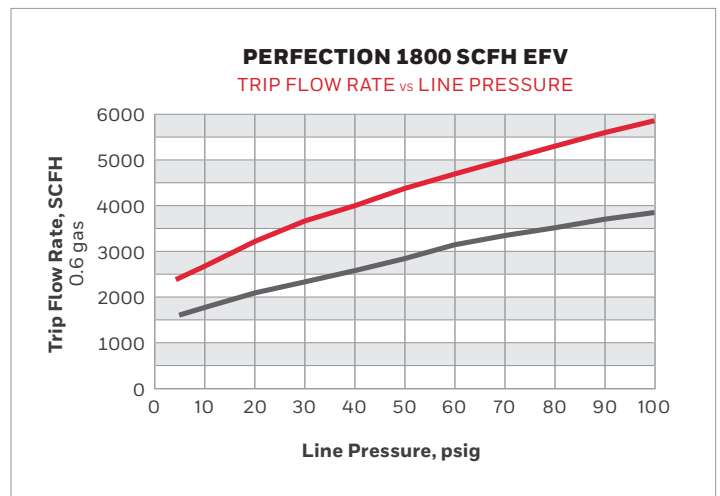
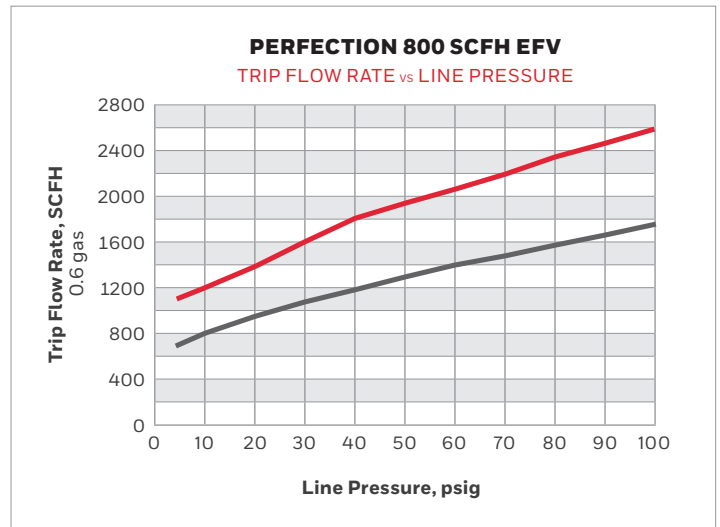
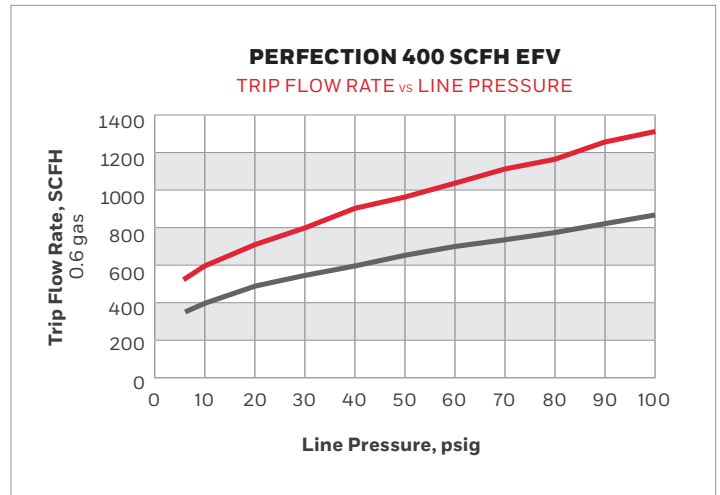

For a detailed specification including additional sizes and flow test results, please contact your local Honeywell Perfection sales representative or Honeywell Perfection directly at 800-544-6344.

COST-EFFECTIVE, ALL-WEATHER SIMPLICITY

Permasert™ XL couplings offer the same advantages as Permasert 2.0 couplings – fast, cost-effective installation with the security of a safe, gas-tight connection. Permasert XL plastic couplings are non-corrosive and save time and money particularly compared to bolt-on metallic couplings or electrofusion fittings.



- Connect new PE lines to PE mains, or easily transition from PVC, steel, or cast iron
- Non-corrosive, gas tight, and no cathodic protection required
- All weather installation and requires only one person, saving time and money

SIMPLE TO INSTALL, EASY TO MAINTAIN

Bolt-on metallic-body couplings require cathodic protection to meet federal requirements and also require stiffeners, anode, or wax tape and tar to install them.

Electrofusion requires more installation time for surface preparation, dealing with misaligned pipe, and fusion cool time. Electrofusion also requires extra costs for a larger ditch with increased excavation and restoration, as well as time lost sheltering the fusion process in poor weather conditions. If transitioning from steel or cast iron to PE, a transition fitting is required as well. By contrast, Permasert XL couplings are ready to go in the ground as shipped. You'll also gain significant labor savings, given the time to completely install a metallic fitting, its anode, and protective coatings.

Likewise, Permasert XL couplings require no future costs for anodic cell monitoring and maintenance.



PLASTIC MECHANICAL COUPLINGS

	Permasert® XLP PE-to-PE			Permasert® XLS PE-to-STEEL			Permasert® XL PVC PE-to-PVC			Permasert® XLC PE-to-Cast Iron		
	Size	Part #	Rating	Size	Part #	Rating	Size	Part #	Rating	Size	Part #	Rating
2 IPS	SDR 11.0	55161	Category 1	SDR 11.0	55164	Category 1	SCH 40 PVC and SDR 11.0 PE	55167	Category 1	SDR 11.0	55171	3,500 lbs.
	SDR 9.0/9.3	55162	Category 1	SDR 9.0/9.3	55165	Category 1				2.45-2.60 inch (Cast Diameter)		
							SDR 21 PVC and SDR 11.0 PE	55168	Category 1			
3 IPS	SDR 11.0/11.5	55131	Category 1	SDR 11.0/11.5	55140	Category 1						
	SDR 9.3	55132	Category 1	SDR 9.3	55141	Category 1						
	SDR 13.5	55133	Category 1	SDR 13.5	55142	Category 1						
4 IPS	SDR 11.0/11.5	55101	Category 1	SDR 11.0/11.5	55121	Category 1	SCH 40 PVC and SDR 11.0 PE	55157	Category 1	SDR 11.0/11.5	55151	14,000 lbs.
	SDR 9.3	55102	Category 1	SDR 9.3	55122	Category 1				SDR 9.3	55152	14,000 lbs.
	SDR 13.5	55103	Category 1	SDR 13.5	55123	Category 1	SDR 21 PVC and SDR 11.0 PE	55158	Category 1	SDR 13.5	55153	14,000 lbs.
										4.74-4.87 inch (Cast Diameter)		
6 IPS	SDR 11.0	55183	Category 1	SDR 11.0	55187	Category 1				SDR 11.0	55191	20,000 lbs.
	SDR 11.5	55182	Category 1	SDR 11.5	55186	Category 1				SDR 11.5	55192	20,000 lbs.
	SDR 13.5	55181	Category 1	SDR 13.5	55185	Category 1				SDR 13.5	55193	20,000 lbs.
										6.83-7.00 inch (Cast Diameter)		
8 IPS	SDR 11.0	55196	30,000 lbs.									
	SDR 11.5	55197	30,000 lbs.									
	SDR 13.5	55198	30,000 lbs.									

PRESSURE RATING: 125psig, or the pressure rating of the installed pipe, whichever is lower.

Permasert XL fittings meet DOT 192.283 and ASTM D2513.

MAXIMIZE SAFETY AND VALUE

Honeywell Perfection developed the industry's first plastic / steel anodeless service-line riser in 1972. Today, nearly 20 million Honeywell Perfection risers have been installed worldwide, and we continue to develop a wide variety of riser products to meet your unique installation requirements at an exceptional value.



ANODELESS SERVICE-LINE RISERS

Our risers enable you to make a permanent meter-set connection that requires no cathodic protection – with many standard or custom options to choose from

- Below grade secondary fire seal – protect from gas leaks in case of damage to upper seal
- Available with Permasert couplings or fusion outlets below grade
- End to end coating with consistent thickness
- Prebent, straight or flexible configurations
- Servi-Sert™ stab fitting on flexible riser leverages trusted Permasert™ technology to connect to the above grade NPT thread, eliminating the need for a compression style fitting
- Available ½" IPS to 12" IPS pipe sizes



SINGLE OR DOUBLE SEAL RISER

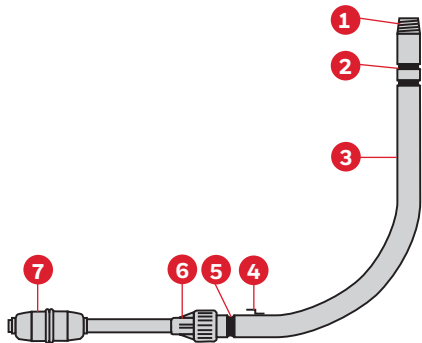

- 1 NPT Threads
- 2 Primary Gas Seal
- 3 Steel Pipe Casing
- 4 Trace Wire Clip (opt.)
- 5 Secondary Gas Seal (opt.)
- 6 Moisture Seal
- 7 Permasert® Coupling (opt.)

SPECIFICATIONS

Perfection risers meet or exceed the requirements of ASTM D2513 category 1, ASTM F1973, ANSI B 1.20, ANSI B 31.8, US DOT Part 192, NFPA-58 and CSA B137.4.

SIZE

Pipe: 1/2" IPS to 12" IPS ASTM A53 type F or E grade B, schedule 40 and 80

Tubing: 1/2" CTS to 12" IPS medium or high density polyethylene

OUTLETS

Threaded, Weld-end, Flange, By-pass

SERVI-SERT TOP CONNECTION RISER

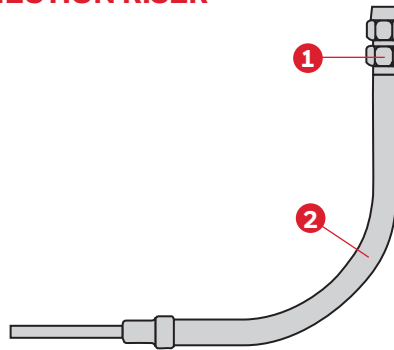

- 1 Servi-Sert Fitting
- 2 Prebent or Flexible Casing

SPECIFICATIONS

ASTM D 2513 category 1, ANSI B1.20, ANSI B 31.8, US DOT Part 192, NFPA-58 and CSA B137.4.

SIZE

Outlets from 1/2" NPT to 1 1/2" NPT

PE Inlets from 1/2" CTS to 1 1/4" IPS

REUSE WHAT YOU CAN, REPAIR WHAT YOU NEED

Honeywell Perfection products for repairing and installing natural gas service lines and distribution components are cost-effective and easy to install.

Our long-standing, cooperative relationships with utility partners have enabled us to develop an innovative range of retrofit options that help you overcome common challenges and increase your daily efficiency. For instance, our Retrofit line of products are designed to let you replace only the deteriorating portion of a service line, reducing your costs while also minimizing excavation and site work.

DEVELOPED WITH AND FOR UTILITIES

- Safely recycle most of your existing non-gas carrying components.
- Proven technology for reliable, long-term performance.
- Significantly reduce your costs – up to 50%.
- Minimize your excavation, restoration, and installation time using keyhole technology.



SERVI-SERT RETROFIT ADAPTER

Specially designed to replace the outlet while salvaging the welded steel mainline tee. Simply remove the compression nut on the current tee and attach the female NPT threads of Servisert™ Retrofit adaptor. Then, stab the polyethylene service line into the Servisert™ adaptor with Permasert™ technology.

- Permanent, leak free connection
- Cost savings of 25% or more compared with welding a new tee



BRASS BASE SERVICE TEE

For existing main lines with threaded ports, the Brass base service tee provides a corrosion-resistant connection to a metallic main with a PermaTite cap for easy, hand-tightened installation.

- Brass base tee swivels after threading to cast iron main
- 1" and 1/4" IPS base threads
- Permasert outlet for fast, safe connection



CUT-IN CURB VALVE

Fast, easy installation of a shutoff valve into an existing service or main line. Often used for additional safety, non-pay situations, or to replace metallic valves on PE service.

- Available in ¾" IPS through 2" IPS
- Telescoping Permasert™ coupling allows for easier installation on existing services.



SERVI-SERT INTERCHANGE RISER

A safe, cost-effective way to replace service-head adapter-style risers.

- Time-proven Permasert process for leak free connections
- Faster than standard riser excavation and replacement – 30 minute installation time



ANODELESS RISER REPAIR KIT

Repairs anodeless risers buried in concrete or other situations where excavation is difficult and costly.

- Completely replaces old transition joint with leak-free servi-sert connection

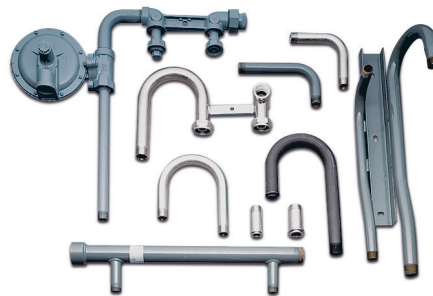

PREFABRICATED METER SETS

Save time and hassle by purchasing custom meter sets, manifolds and components from Honeywell

- Standard coating is polyester over e-coated paint, for superior UV and impact protection
- Available in standard or "custom" meter set configurations based on your needs
- Multi-meter manifolds allow up to 10 drops with fewer threaded joints
- Prebent and threaded ells and loops available

THE COMPLETE MAIN TO METER SYSTEM

The Permasert 2.0 family of easy-to-install products enables you to make fast, safe piping connections without requiring special tools or expensive equipment. Permasert 2.0 products can be configured for virtually all gas-distribution applications.



A Anodeless Service Line Risers and Transition Fittings - see page 12

B PSV Polyethylene Shut Off Valves - see page 15

C EFV Excess Flow Valves - see page 8

D Permasert 2.0 Couplings - see page 4-5

E Servi-Sert™ Fittings - see page 15

F Permalock™ Mechanical Tapping Tees - see page 6

Also available:

Prefabricated Meter Sets and Steel Products - see page 15

Custom Fittings and Accessories - see page 14

For more information

pmt.honeywell.com/us/en/businesses/smart-energy

Honeywell Smart Energy and Thermal Solutions

2101 CityWest Blvd, Houston, TX 77042

All Permasert 2.0 configurations meet or exceed the requirements of ASTM D2513, US DOT Part 192, and CSA B137.4.

GPF-BR-NAEN-0001-Perfection

BRO-23-46-EN | 06/23
© 2023 Honeywell International Inc.

THE
FUTURE
IS
WHAT
WE
MAKE IT

Honeywell