

# HONEYWELL AMERICAN METER AC-250 NXS SYSTEM

## Smart Gas Metering System

The American Meter AC-250NXS Diaphragm Meter is the new standard for accurate, reliable and safe residential gas metering, delivering high performance measurements at an economical price. As first-world-class smart diaphragm gas meter on the market, it is easy to install and fits in tight spaces, such as meter trees in apartment complexes.

Honeywell/Elster's trusted diaphragm meters have been sold for 150 years. The AC-250NXS smart gas meter incorporates our unsurpassed expertise in gas metering and utilizes the same proven diaphragm meter technology as our legacy meters.

With a gas-tight, integrated shutoff valve linked to onboard pressure and temperature sensors, the meter enables an almost instant, autonomous shutoff response to system anomalies such as over-pressure, high-flow, leakage, or fire. The AC-250NXS features a field-replaceable battery with a 20-year operating life and is a direct-fit replacement for the AC-250.



## GAME CHANGING SOLUTION



### Cellular IOT technology

Next-generation LPWAN networks eliminate the need for the installation of a costly and inefficient private network. Provide Universal standard and extension coverage.



### Intelligent shutoff valve and overpressure protection

Autonomous or utility triggered gas shutoff in response to a variety of gas network system anomalies. Overpressure protection functionality drives significant safety transformed



### Advanced Connexo Software Solutions

The Honeywell Connexo suite enables seamless deployment and integration



### Proven diaphragm meter technology

+100 million install base with proven diaphragm for +30 years experience

## PRODUCT FEATURES

- Class I, Division I, Group D, Temp Class T1
- Reliable proven diaphragm measuring unit with over 100M installed base
- Built-in temperature compensation for high accuracy of the measurements
- 20-years of battery life with integrated 2 D-Size batteries when using recommended operating parameters.
- Reliable communication with Head End System (> 99% communication success)
- Public wireless and CAT-M1 communications module
- Part of Honeywell connected utilities eco system, integrated into Honeywell Connexo Meter Data Collection (MDC) and Meter Data Management (MDM) system

## PRODUCT COMPONENTS

The AC-250NXS Gas Meter features these components in a compact meter:

- AC-250NXS Gas Meter index
  - The index contains the Cat-M1 communications module, two batteries, one battery is replaceable. The liquid crystal display (LCD). The LCD provides a visual display of consumption, alarm messages, and status information.
- An internal shutoff-valve
- Diaphragm measuring unit
- Integrated metrological unit with optical pickup
- Die cast aluminum case and
- Steel bosses

- Honeywell MeterSense maintenance handheld tools for easy maintenance of the device via optical communication.
- Highly secured with end-to-end industry standard encryption and authentication methods.
- Honeywell SNAP prover integration with electronic accuracy adjustment
- Safety features:
  - Reliable, bubble tight valve
  - Autonomous shut off based on high pressure, high temperature, tamper and high flow rate.
  - Safety alert to Head End system during valve closure/open
  - High flow rate alarm
  - Reverse flow detection and alarm
  - Remote valve shut off
  - High response mode (communicates every 15 minutes during emergency situations like High Pressure, High Temperature, High Flow or Valve closure)
- In-field changeable battery.
- Metrology integrated inside the meter independent from communication module. Enabling communication module to be interchangeable/replaceable in the field (not yet implemented)
- Volume, pressure, temperature and meter status reporting for Head End analytics
- Over The Air (OTA) firmware upgrades for communication and metrology
- Local standardized optical service port for infield diagnosis, valve operation and re-calibration

## AC250 NXS SHUT OFF VALVE

Safety is paramount in gas metering, and each Honeywell American Meter is available with the AC-250NSX Shutoff Valve. Unlike competitive devices prone to gas leakage, this secure, integrated safety shutoff valve has a high-torque, precision seal that exceeds ASME B16.33 guidelines for gas-tightness and comes with FCC, UL Class 1 Div1, IP67, and 250 Class approvals to meet ANSI standards.

The AC-250NXS Safety Shutoff Valve employs on-command shutoff to meet storm hardening, non-payment, delinquency, and move-in/move-out requirements. The valve's autonomous shut-off response and alarms are linked to configurable triggers for high or low pressure, high or low flow and high temperature and fire, and peripheral sensors are provided for methane, seismic activity, corrosion, flooding, and other indicators. Capabilities are also included to monitor mechanical pressure regulator health.

The key features and benefits of this reliable safety shutoff valve include:

- Remote disconnection of the gas supply
- Automatic gas disconnection on high-pressure/temperature events
- Single fault-tolerance against unintentional opening of the valve
- Gas re-enabled only once all of the customer's gas appliances are closed
- No energy consumed when valve is open or closed
- Low energy consumption during valve movement
- When valve is closed, it resists at 60 PSI pressure
- Detection of open and closed positions (patent pending solution)
- Configurable valve operation (e.g., valve closure thresholds)
- Located in the meter outlet (robust protection against dust)
- Closes in flow direction (remains tight with increasing pressure)
- Designed for more than 4,000 open/close cycles
- Tamper detection algorithm
- Several million installations in Europe and elsewhere
- Flow check algorithm enables remote opening of the valve in a safe manner



## AC250NXS INDEX

- Low cost, integrated Cat-M1 cellular communications including a 20-year data plan embedded in the meter purchase price and managed by Honeywell over the lifetime of the contract.
- “1.5”-way communications with:
  - Communication always initiated by the meter, when initiated full 2-way comms
  - Valve status alarm.
  - Pressure & Temperature Alarms with Hi/Lo configurable alarm limits.
  - Battery health and battery alarm.
  - Tamper alarm with valve closure enablement for reverse flow, cover opening, & detachment of index from meter.

Over the air firmware updates.

- Field replaceable Lithium primary Battery
- No mechanical blocking of mechanics or rotating parts possible. Optical sensor utilized and no moving mechanical
- parts inside of the index.
- Current, Daily, Billing Period and Metrological Diagnostic Status available for easy remote diagnostics.
- Integrated pressure sensor for “stolen meter” detection

## AC-250NXS GAS METER SPECIFICATIONS

SPECIFICATION	VALUE
Flow rate	250 CFH at 0.5in w.c.
Measurement principle	Molded, convoluted diaphragm
Safety	Class I, Division 1, Group D, Temp Class T1
Meter type	Temperature compensated (TC) or Non-Temperature Compensated (NTC)
Meter Maximum Allowable Operating Pressure (MAOP)	5 PSIG (345 mbar)
LCD displayed units	CCF (100 x cubic foot)
LCD resolution	000000.001 CCF
Valve	maximum 0.035 CFH (1 L/H) leakage rate at max 2PSIG diff pressure
Case	Die-cast aluminum case
Weight	12 lbs.
Gas type	Natural gas EN437- Type H,E,L Reference gases G20, G21, G23, G25, G26, G2
Connection sizes	10 LT, 20 LT, 30 LT, 1" PITTS, 1" Sprague
Operating temperature ratings	Measurement -30° F (-34° C) to +140° F (60° C) Valve -13° F (-25° C) to +131° F (55° C) Index -40° F (-40° C) to +158° F (70° C)
Storage temperature	40° F (-40° C) to +158° F (70° C)
Battery information	2 Lithium Thionyl Chloride 'D' cell batteries, One battery is replaceable
Battery life	20 years for both metrology and index communication (under recommended operating conditions) without battery change
Standards	Designed in compliance with ANSI B109.1, ANSIB109.0
Regulatory	This device complies with Part 15 of the FCC rules. FCC ID: XMR2020BG95M2
Component materials	Single coat polyester

## DIMENSIONS

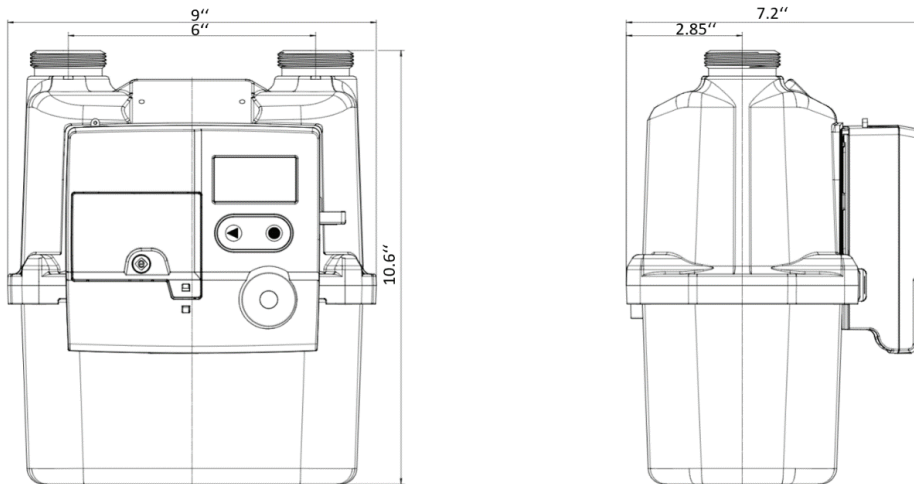

## PROOF CURVE

AVERAGE ACCURACY			
25	50	200	245
100.7	100.1	100.2	99.9

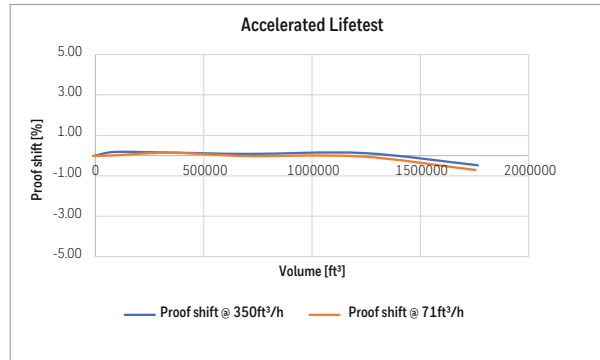
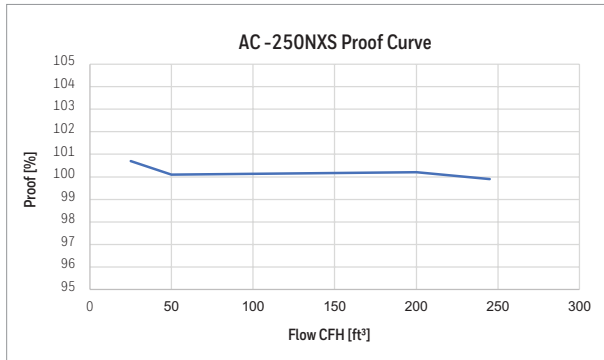

CAPACITIES* (0.60 SPECIFIC GRAVITY GAS)		
LINE PRESSURE PSIG (mbar)	DIFFERENTIAL INCHES W.C. (mbar)	CAPACITY SCFH (m³/h)
0.25 (17)	1/2 (1.2)	250 <sup>1,2</sup> (7.1)
1 (69)	2 (5)	598** (16.9)
2 (138)	2 (5)	597** (16.9)
5 (345)	2 (5)	598** (16.9)
10 (690)	2 (5)	601** (17.0)

<sup>1</sup> Propane - 158 SCFH (4.5 m³/h)

<sup>2</sup> Butane - 138 SCFH (3.9 m³/h)

\*Capacities determined with connection sizes as specified by ANSI B109.1

\*\*Operating this meter above its rated capacity (250SCFH at 1/2" differential W.C.) could impact the long-term performance and reliability

### For more information

To learn more about Honeywell's gas metering and control solutions, visit [www.smartenergy.honeywell.com](http://www.smartenergy.honeywell.com) or contact your Honeywell account manager.

### Honeywell Smart Energy

2101 CityWest Blvd. Houston, TX 77042  
[www.honeywell.com](http://www.honeywell.com)

DTS-20-11-EN | Rev02 | 04/22  
 © 2022 Honeywell International Inc.

THE  
 FUTURE  
 IS  
 WHAT  
 WE  
 MAKE IT

**Honeywell**